



**Mounting of rolling bearings  
Mounting of drawn cup  
needle roller bearings**

# Mounting of special types

**Features** Selection of the suitable mounting method is based not only on the bearing type but also on the adjacent construction and the relevant dimensions. In the case of some rolling bearing types, attention must be paid during mounting to particular features or a particular procedure must be applied, which is discussed in detail below. Further details are given in the product-specific catalogues and brochures. The decisive factor for correct mounting is, however, the mounting manual relating to the application.

## Mounting of drawn cup needle roller bearings

Due to their thin-walled outer ring, drawn cup needle roller bearings adopt their exact form as a result of tight housing fits, eliminating the need for lateral location.

Special mounting mandrels are used for pressing in drawn cup needle roller bearings. The mandrel normally rests against the stamped end face of the bearing, which is hardened in the case of smaller bearings. Even if the bearing is pressed in via an unhardened rib, this will not lead to deformations or jamming of the needle roller and cage assembly as long as the mandrel is correctly dimensioned.

## Radial and axial location

Drawn cup needle roller bearings are located in the housing bore by means of a press fit. They are pressed into the bore and require no further axial retainers.

## Mounting using pressing mandrel

The bearings should be installed using a special pressing mandrel, *Figure 1*. The shoulder of the pressing mandrel must rest against the end face of the bearing. This is indicated by the designation.

A toroidal ring should be used to retain the bearing. The length and oversize of the ring must be matched by the customer to the dimensions and mass of the bearing.

If grease lubrication is to be used, the bearings should be lubricated with grease before mounting.



Drawn cup bearings must not be tilted while they are being pressed in.

The forces occurring during pressing-in are dependent on several factors. Mounting must be carried out so that the bearing rib on the end face is not deformed.

If the application requires a mounting procedure different from the one described, mounting trials must be carried out in order to ensure that the bearings can be mounted correctly and without causing damage.

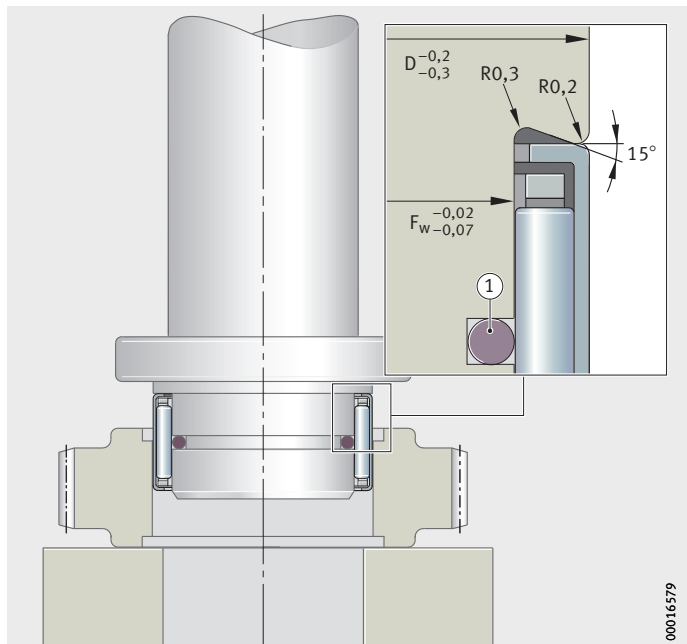

① Toroidal ring

*Figure 1*  
Mounting using pressing mandrel

## Further information

This PDF file is part of “medias” (medias.schaeffler.de). Please also take note of all other information provided there (Internet pages, PDF files), where this information is applicable to your task.?

**Schaeffler Technologies  
AG & Co. KG**

Industriestraße 1–3  
91074 Herzogenaurach  
Germany  
Internet [www.schaeffler.de/en](http://www.schaeffler.de/en)  
E-mail [info.de@schaeffler.com](mailto:info.de@schaeffler.com)

In Germany:

Phone 0180 5003872  
Fax 0180 5003873

From other countries:

Phone +49 9132 82-0  
Fax +49 9132 82-4950

**Schaeffler Technologies  
AG & Co. KG**

Georg-Schäfer-Straße 30  
97421 Schweinfurt  
Germany  
Internet [www.schaeffler.de/en](http://www.schaeffler.de/en)  
E-mail [faginfo@schaeffler.com](mailto:faginfo@schaeffler.com)

In Germany:

Phone 0180 5003872  
Fax 0180 5003873

From other countries:

Phone +49 9721 91-0  
Fax +49 9721 91-3435

Every care has been taken to ensure the correctness of the information contained in this publication but no liability can be accepted for any errors or omissions. We reserve the right to make technical changes.

© Schaeffler Technologies AG & Co. KG  
Issued: 2017, September

This publication or parts thereof may not be reproduced without our permission.  
MH 1 GB-D